

WET GRINDING AND MILLING WITH A PLUS.

The best seller,
plus extra cooling.



Visibly
different
Noticeably
better

4
Axes

3
Blocks

8
Tools

Wet

Mill
Grind

CAM
Software
incl.

VISIBLY DIFFERENT, NOTICEABLY BETTER: WITH WATER-COOLED SPINDLE.

Thanks to its striking, updated look, the new N4+ is an eye-catching choice in any laboratory. We have also equipped it with a water-cooled spindle. That means you benefit from improved process stability, and you can always rely on first-class results even in continuous operation.



Did you know?

vhf has been using high-quality 4-fold hybrid ceramic bearings for over ten years, particularly for machining metals. For you, this means a significantly longer spindle service life, higher surface quality and noticeably better accuracy of fit.

PROVEN ADVANTAGES OF OUR BEST SELLER.



The essence of wet grinding

The N4+ is an efficient wet processing machine for grinding and milling glass ceramic, composite, and zircon blocks, as well as CoCr and titanium abutments. It impresses not only thanks to its high precision and fast drives, but also thanks to its ultra-compact housing with closed fluid circuit. Eight fine nozzles on the spindle direct the cooling liquid precisely onto the effective area between the tools and workpiece, delivering an optimal cooling effect.

The N4+ also has plenty of power. The machine's spindle offers 800 watts of power, achieving up to 80,000 rpm. That allows for efficient wet processing of up to three blocks or prefabricated abutments.



Tool changes in a flash

The tool magazine can be inserted quickly and effortlessly in just one step. The automatic changer offers space for up to eight tools. The three compartment block holder is another highlight. That makes the N4+ the ideal partner for research and practice laboratories.



The large fluid tank can easily be removed from the drawer.

FEATURES AND BENEFITS? LOTS OF THEM!



Exceptional precision

- Restorations in Ultra HD
- Premium spindle with four-fold ball bearing made of hybrid ceramic for the highest concentricity
- 3 μm repetition accuracy



Absolute independence

- Around 40 block materials from a great variety of manufacturers – with upward tendency
- >1,300 implant platform for titanium and CoCr prefab abutments from different manufacturers
- Ideal for labs and in-office labs



Sophisticated design

- Spindle with water cooling for perfect results, even in continuous operation
- Eight liquid nozzles for steady tool cooling
- Highest rotational speeds of up to 80,000 rpm with 800 watts of power
- Heavy industrial quality



Outstanding reliability

- 100% developed and manufactured in Germany
- 24 months warranty



Highly economical

- **PUREWATER:** no grinding additives necessary, except for titanium processing
- Work on up to 3 blocks with 45 mm length at the same time
- Milling of screw channels – saves costs for meso blocks
- Conveniently removable cooling liquid tank
- Automatic changer for 8 tools
- Webcam in working chamber for remote monitoring and service
- Ethernet interface for stable connection
- Very easy operation via DENTAL-CAM software with DIRECTMILL-Function – included in scope of delivery and without license fees



Scientists at the University of Washington confirmed an outstanding precision of $-10 \mu\text{m}$ to $+26 \mu\text{m}$ during demanding applications like milling titanium abutments.

YOU CHOOSE: MATERIAL, MANUFACTURER, INDICATION.

All common block materials up to 45 mm in length and even abutments

Composites	Plastics Wax	Glass ceramics	Zirconia	Titanium	CoCr
------------	----------------	----------------	----------	----------	------

High-precision milling and grinding for all common indications

Crown Bridge	Inlay Onlay	Abutment	Telescopic crown	Model plate
Model cast	Occlusal splint	Model tooth die	Implant bar	Veneer
Drilling template	Denture	Secondary crown	Screw-retained bridge	Protrusion splint

Be sure to review local and/or national regulations and/or regulations by other authorized organizations or entities (e.g. professional associations, health authorities).

A MATTER OF FACTS.

GENERAL	
Fields of application	Wet machining
Materials	Glass ceramics, titanium, zirconia, composites, plastic materials • Blocks up to 45 × 20 × 20 mm
Indications	Crowns, bridges, fully anatomical crowns and bridges, inlays, onlays, abutments, veneers, table tops
BASE SYSTEM	
Construction	Machine bed made of solid cast aluminum body
Housing	Sheet steel housing, white high-gloss lacquer finish, with working chamber flap and cooling liquid tank integrated in the drawer
Number of axes	4
Linear axes	Precision ball screws · motors with resolution < 1 µm · ground precision guides made of steel · repetition accuracy ± 0.003 mm
Rotary axis	Rotary axis with high run-out accuracy · rotation angle: 200°
A-axis	
Control unit	4-axis simultaneous control electronics with continuous path progression and dynamic pre-calculation · hardware-based real-time operating system with standardized command set · FPGA-integrated processor · updateable hardware · real-time path calculation via dedicated hardware engines in the FPGA · four-quadrant control of the motors for particularly smooth running · multiple analogue and digital I/Os for controlling the peripherals · integrated inverter for synchronous and asynchronous motors, electronic gate detection · Ethernet and USB interface
Lighting	RGB LED lighting with status display
Camera system	Integrated in the working chamber for easy remote support and possibility of internal recording
SPINDLE	
General	High-frequency spindle, synchronous, with pneumatic tool clamping · sealing air to prevent debris from entering · automatic cone cleaning
Speed	Up to 80,000 rpm
Power	Peak power (P _{max}): 800 watts · nominal power (S6): 600 watts · continuous power (S1): 440 watts
Bearing	4-fold hybrid ceramic ball bearing · concentricity deviation at inner cone < 3 µm
Collet	Stainless steel collet with ceramic coating for tools with 3 mm shank diameter and max. 35 mm total length
AUTOMATION	
Tool change	Tool magazine for 8 tools, removable · length measurement and tool breakage monitoring via precision measuring key · access through working chamber door, safety lock
PROCESSING MODES	
Wet	Multiple fluid nozzles on the spindle · integrated cooling liquid tank (3.5 litres) with active carbon filter system · flow-sensor for monitoring the liquid supply · PUREWATER : no grinding additives necessary, except for titanium processing
CONNECTION REQUIREMENTS	
Compressed air	4 bar: 25 l/min up to 8 bar: 45 l/min · air purity according to ISO 8573-1:2010
Power	100 – 240 volts · 50/60 Hz, 640 watts
Data	10/100/1000 MBit/s BaseT port (auto-sensing) Ethernet via RJ-45 socket
ENVIRONMENTAL CONDITIONS	
Operating temperature	Between 10 °C and 35 °C
Air moisture	Max. 80 % (relative), non-condensing
APPROVALS	
All models	CE, VDE
North America model	UL 61010-1, CAN/CSA C22.2 No. 61010-1 (pending)
DIMENSIONS & WEIGHTS	
Dimensions (W/D/H)	364 × 460 × 473 mm with closed flap and drawer
	364 × 667 × 473 mm with open flap and drawer
Footprint (W/D)	337 × 324 mm
Weight	52 kg
SCOPE OF DELIVERY	
CAM Software	DENTALCAM software included
Holder systems	Abutment holders for various systems (optional)
Accessories	Spindle service set · calibration set incl. micrometer · Tec Liquid set · brush for nozzle plate · cleaning brush · spare fine filter · active carbon pellets · Tec Powder (3 bags) · tool magazine inserts (2 pieces) · spare screws blank holder · torque wrench · emergency release key · drill bit (tool positions) · measuring pin · compressed air hose with pressure reducer · power cable · Ethernet network cable · carrying aid for transporting the machine · operating manual

Subject to changes and errors.

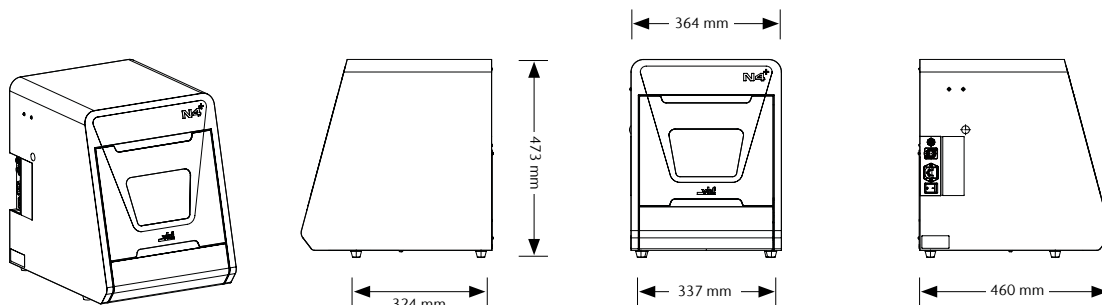

YOUR PLUS FOR WET GRINDING: N4+

PERFORMANCE CLASS

PERFORMANCE CLASS machines are top performers in dental laboratories, and allow labs to work with outstanding efficiency. In this series, we offer all dry and all wet processing machines, as well as a combination of the two.

The optimal addition

The K5+, used for dry milling discs, is the ideal addition to the N4+ wet grinding machine. Combined, the two machines can handle almost any indication.



WHAT DO THEY SAY IN EVERYDAY PRACTICE?



The ideal machine for all practice labs who want to provide quality restorations to their doctors quickly and easily.

Janine Sparks, CDT
University of Maryland,
Baltimore, USA



I was surprised how easy to operate and how reliable the N4+ is. The workflow is unbelievably fluid, in particular when milling disilicate crowns on implants, veneers, and inlays.

Ricardo Schäfer
Founder and Manager of
Schäfer Dental+Lab, Buenos
Aires, Argentina



CREATING PERFECTION.

With 35 years of experience, vhf is a leading manufacturer of dental milling machines. As a CAM full-service provider, vhf meticulously develops and produces each individual milling machine and the perfectly matched tools and software all in-house. Everything from a single source. Made in Germany.

Service. We are passionate about what we do.

Our products are extremely low-maintenance and highly durable, but the servicing of your machine is important to us. We provide customer support with our user-friendly DentalPortal, numerous online tutorials and personal assistance through our international service network.

GET IN TOUCH.

Headquarters

vhf camufacture AG
Lettenstraße 10
72119 Ammerbuch, Germany
+49 7032 97097 000
info@vhf.de | vhf.com

North America

vhf Inc.
80 Davids Drive, Suite 5
Hauppauge, NY 11788, USA
+1 631 524 5252
info@vhf.com | vhf.com

Asia

vhf Trading (Shanghai) Co., Ltd.
Room 2902, Building T1, Tianshan SOHO,
No. 421 Ziyun Road, Changning District,
Shanghai, China
asia@vhf.de | vhf.com



vhf.com/N4plus-en

